

## Ignition 9519300S3



- Do NOT replace generator!



**Advantage over original system**

## Electronic ignition for MZ ETZ

- This is an exception system, only 1 out of 200 ETZ alternators demand this.

- Imperatively do the compass test to verify that you really need S3 and not the standard S1.

- For all 2-stroke ETZ (125/150, ETZ250/251/301)

- Needs original 3-phase generator as base!

- Fully electronic, solid state ignition. Replaces points or other electronic ignition in ETZ (such as ESE und PVL). There is no need for changes on engine casing. You need a working battery.

- Please note our remarks on direction of magnetic field. Ignition for 9519300S1.

- System is available (ESE and PVL parts or not)
- all parts are new
- very stable ignition with solid spark
- better starting, better fuel burning
- no huzzle anymore with setting points

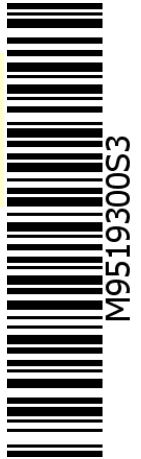

<b>Assembly instructions for system 9519300S3</b>	<b>12.8.2024</b>
<p><b>- If you can install and time a stock ignition and possess basic mechanical skills, you can install a VAPE! If you never have worked on your ignition, better have it done by someone who knows.</b></p>	
<p>- VAPE can not monitor the compliance to those instructions, nor the conditions and methods of installation, operation, usage and maintenance of the system. Improper installation may result in damage to property and possibly even bodily injury. Therefore we assume no responsibility for loss, damage or cost which result from, or are in any way related to, incorrect installation, improper operation, or incorrect use and maintenance. We reserve the right to make changes to the product, technical data or assembly and operating instructions without prior notice</p>	
<p style="text-align: center;"><b><u>IMPORTANT</u></b></p>	
<p><b>- Please read these instructions fully and carefully before starting work on your motorcycle</b> Please bear in mind that any modification of the material as well as own repair attempts which have not been agreed with VAPE may result in a loss of warranty. Do not cut off wires. This leads to a loss of reverse polarity protection and often results in damage to electronics. Also, please take note of the information provided on the information page for this system. Check that what you have bought really corresponds to the motorcycle you have. Wrong ignition settings may damage your engine and even hurt you during kickstart (violent kickbacks). Be careful during the first test runs. If needed change settings to safer values (less advance). During assembly check carefully that the rotor (flywheel) does not touch the stator coils or anything else, which may happen due to various circumstances and lead to severe damage.</p>	
<p><b>Designated use</b> - This system is designated to replace stock dynamo/alternator &amp; ignition systems in vintage and classic motorcycles <b>whose engine characteristics have not been modified aftermarket</b>. This system is not a tuning system and it will not bring significant increases in engine output. It does however significantly enhance roadworthiness and comfort by offering better lighting, better function of side indicators and horn and, compared with the aging stock systems, increased reliability. As our system does not tamper with engine characteristics it does not increase emission of gaseous pollutants and noise. In most cases emission of pollutants should even be reduced due to better combustion. If used as designated the system therefore will not normally infringe the existing legal status of the motorcycle (this statement is valid for Germany, for other countries, please check locally against your road licensing regulations). This system is not suitable for use in competition events. If used other than the designated way, warranty will be voided and it might well be that you do not obtain the desired results or, worst you loose legal roadworthiness.</p>	
<p> <b>- VAPE guarantees homologated products marked with the “E” mark in the ring (E8 specifically for the Czech Republic), thereby ensuring a consistent conformity of the product properties with the relevant ECE homologation regulations (especially ECE R10.05). Inspection is regularly carried out by the competent authority.</b></p>	
<p><b>- The charging system is only suitable for use with rechargeable 12V (6V systems 6V) lead-acid batteries</b> with liquide electrolyte or sealed lead-acid batteries, AGM, Gel. It is not suitable for use with nickel-cadmium, nickel-metal-hydride, lithium-ion or any other types of rechargeable or non rechargeable batteries.</p>	
<p>- This is a <b>replacement system and not a copy of the stock material</b>. The parts in this system therefore look different and might fit differently (notably ignition coil and regulator) requiring some adaptation by you.</p>	
<p><b>- During assembly imperatively start with assy of engine based parts</b> to see that those really fit before you start fitting the external parts. In many cases customers assemble those first and thereby often modify them in breach of warranty which renders them unfit for renewed sale. Replacing old ignition systems is not a matter of taking something from a supermarket shelf as there have been very many types, versions and possibly unknown aftermarket modifications which harbour plenty of room for error.</p>	

- Our systems are **NOT tested for use with third party electronic devices (such as GPS, mobile phones, LED lighting etc)and may cause damage to such parts.** Possibly existing electronic tachometers will not work with the new system. Read our information for suitable solutions. Possibly existing safety switches and electronic valve controls are not supported. It might be that your motorcycle was originally equipped with an ignition that did limit top speed for legal reasons. The new system does not have such a facility, so check your legal situation beforehand.

- If you have no expertise for the installation have it done by an expert or at a specialist's workshop. Improper installation may damage the new system and your motorcycle, possibly even lead to bodily harm.

- Before you order a system, please check whether a puller tool for the new rotor is included in the kit. If not, better order it at the same time. Never use anything other than the recommended puller tool to pull the new rotor again. Damage to the rotor as a result of use of other tools or methods is not covered by your warranty.

- The rotor is sensible to blows (including during transport). Before assembly, please always check for damage (on rotor without magnet plastification try to push the magnets aside with your fingers). After impact the glued in magnets might have broken loose, sticking to the rotor solely by magnetic force, so that one does not notice right away. During engine run the damage would be considerable. Before placing the rotor onto the engine, please make sure that its magnets have not collected any metal objects such as small screws, nuts and washers. That equally would lead to severe damage.

- **If you have access to the Internet, best view those instructions online.** You get larger and better pictures by clicking onto them and possibly updated information. System list at <http://www.powerdynamo.biz>



- **If you have not already done before ordering the system,** please check the direction of the magnetic field of your ETZ generator, to find out whether you need, system S1 or S3.

To do that, you have to start the motorcycle - something that hopefully is still possible at that stage, switch on the headlight and run the engine at about half speed (stationary!).

- Now hold a compass (any simple type will do) against the right side of the engine (the dynamo cover may stay in place).

- If the marked end of the needle points towards the engine, the S1 is OK, if the needle points however away from the engine, you need S3.

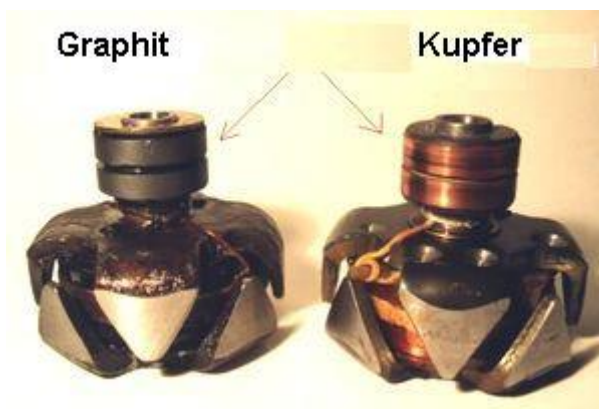

- S3 is really the exception and should only be needed in motorcycles with rotors made after 1991. After that date, unfortunately no attention had been paid to the winding direction. As a result we get magnetic fields inverted by 180°.

- This interferes with our systems and leads to a rapid destruction of the ignition coil.

- Quite often the engine does not start and run well with the wrong polarity.

- **Rule of thumb** if you can not check the field:

If the rotor rings are made of graphite, S1 is correct, if they are made of copper, you have to employ the compass method, there is no other way of telling with those rotors!!



- **You should have received those parts!**

- Note, that the sensor module is only loosely fixed at the base plate, as it has to be adjusted by you.

- Disconnect the battery and better take it off the bike for the time of work to prevent shortcircuits.

- Disconnect the green wire from the points plate or whatever wires you might have at any electronic trigger there. Do not remove that wire however, you will make use of it again.



- Unscrew the rotor bolt and take this long screw M7 off. Rotor and stator housing however remain in place.

- Take the cam (or whatever rotor arrangement for any electronic ignition you might have there) off.

- Take the points plate and the condenser off.

- From the parts taken off, you will only need the long screw M7.

- Take the original ignition coil (and so you have any ignition boxes) off the bike.

Memorize the wires that did run to your ignition coil. With the standard points based ignition those should be a green wire at pin 1 of the coil and 2 red/black wires joint in one ring-terminal at pin 15. Do not cut the 2 wires originally sitting at pin 15. Your stop/tail light would not work anymore.





- Now place the new holder plate with the sensor onto the generator, same place points had been sitting. Fasten with the screws used before for the points.

- Place the new rotor disc onto the rotor (in place of the cam).

- Put the supplied socket on the long screw M7 and screw it back into the rotor. (The socket are needed as the screw is now too long, but getting a long M7 is a headache!) Attention, systems that were delivered before 14/10/2013, took the bush, 6 washers 7.4.

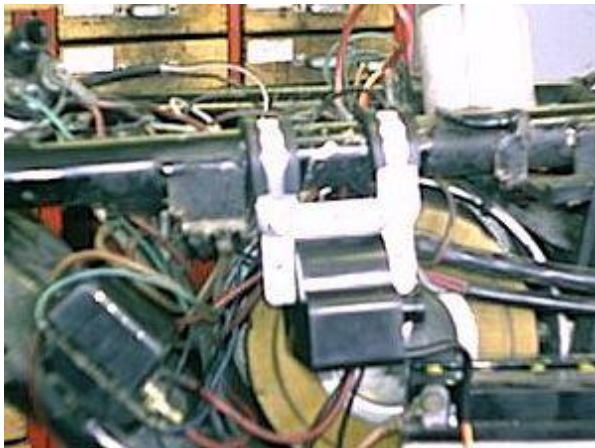

- Fasten the new ignition coil on the rear right tube, directly in front of where the old coil had been fixed to the frame of the ETZ. Use the 2 supplied clamps for that.

- There are physical differences in the frames for the different ETZ versions. On some, you will manage only to install one clamp. In that case, use as additional holding material a cable fixer.

- Do not forget to put the ground wire to the coils metal frame. **Without this ignition will not work.**

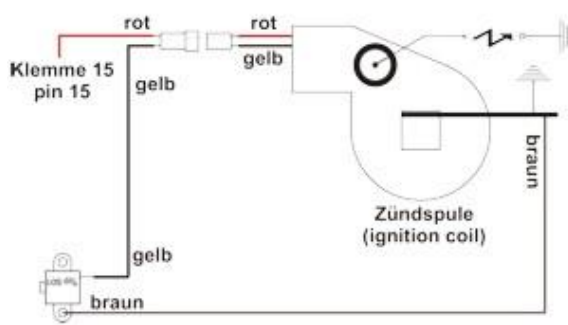

- The red wire of the new coil will be connected to the red/black wire, that did run before to pin 15 of the old coil (arriving from the main switch).

- The old green wire is not been needed anymore.

**- NOTE: Any (even the briefest) confusion between the yellow and red wire of the coil will destroy it on the spot. The same is true for any mixup in connecting the battery. Never connect the batterie's plus to the frame.**

- Now, all is fixed and you may set timing. Note, that you cannot check with a simple light, as you did before on points. **Never use this light check on electronic ignitions, you kill the electronics.** He, who is not happy with the below described method should get himself a stroboscope to check.

- Take the spark plug out and bring the piston into top dead center position (TDC). Turn the crank shaft anticlockwise, so that the pistons falls by nearly 3 mm (2.75 to be precise). There are special tools to help you, but a simple pencil and good eyesight will equally do.

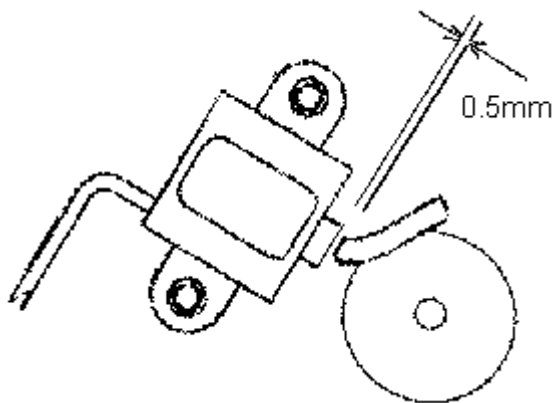

- Hold that piston position and shift the sensor holder plate in such a way that the top left corner of the finger of the new rotor aligns with the pin of the sensor. In that position fasten the sensor plate.

- Check the gap between the sensor and the finger of the rotor. This has to be 0.4-0.6mm. To change that, loosen the 2 sensor screws and shift it. Tighten the screws afterwards carefully! Tighten, even if by chance the gap was correct from start.

**Note: A loose sensor will come into contact with the rotor and get destroyed!**

- Position of rotor finger at moment of ignition.

- Check everything over again, especially wiring. Put the battery in, connect it and start. The system should work.

**Important safety and operating information**

- Safety first! Please observe the general health and safety regulations motor vehicle repair (MVR) as well as the safety information and obligations indicated by the manufacturer of your motorcycle. The timing marks on the material are for general guidance only during first installation. Please check after assembly by suitable means (stroboscope) that settings are correct to prevent damage to the engine or possibly even your health. You alone are responsible for the installation and the correctness of settings.

- Ignition systems generate high tension! With our material right up to 40,000 Volts! This may, if handled carelessly, not only be painful, but outrightly dangerous. Please do keep a safe distance to the electrode of your spark plug and open high tension cables. Should you need to test spark firing, hold the spark plug socket securely with some well insulating material and push it firmly to solid ground of the engine block. Never pull sparkplug caps when engine is running. Wash your vehicle only with engine at standstill and ignition off.

- You should have received the HT Cable with the fixed rubber cap (*which does not contain a resistor*) as a part of the kit, you should have to use a spark plug with an inbuilt resistor (*or replace the cap with the one containing a resistor*) to comply with your local laws (*Electromagnetic compatibility requirements*).

- Do not use a spark plug cap(s) containing a resistor **WITH** a spark plug(s) containing a resistor at the same time. It would cause problems, especially difficult engine starting. The total resistance of cap and spark plug combined should not exceed 5kOhm.

- Remember that candle plugs age, increasing resistance. If an engine only starts when it is cold, it is very likely that a defective spark plug connector or faulty spark plug is the cause. Do not use so-called ignition-reinforcing cables (e.g. Nology).

- After installation, please check tightness of all screws, even those preinstalled. If parts get loose during run, there will be inevitably damage to the material. We pre-assemble screws only loosely.

- Give the newly installed system a chance to work, before you start to check and test values, or what is worse apply changes to it.

Our parts have been checked before delivery to you. You will not be able to check much anyway. **At any rate do refrain from measuring the electronic components (such as ignition coil, regulator and advance unit). You risk severe damage to the inner electronics there. You will not get any tangible results from the operation anyway.** Bear in mind that also your carburetor, your spark plugs and spark plug sockets (even if completely new) might be the reason for malfunction. The general experience with our systems is that the carburetor will have to be re-adjusted to lower settings. Should the system not start after assembly, first disconnect the blue (or blue/white) cut-off wire directly at the ignition coil (or in some cases advance unit) to eliminate any malfunction in the cut-off circuitry. Check ground connections carefully, make sure there is a good electrical connection between frame and engine block. In case of troubles, please consult our Knowledge Base first before you send off the material to us for checking.

- The spark of classic, points based ignition systems has with about 10,000 Volts comparatively little energy and looks therefore yellow and fat (which however makes it highly visible). The spark from our system is a high energy spark with up to 40,000 Volts and therefore is needle thin focused in form, and blue in colour, which makes it not so visible. Furthermore you get spark only at kick-start operated speeds and not by pushing the kick-lever down slowly with your hand (as you might get with battery based ignitions).

- Systems using a twin outlet ignition coils have a few peculiarities. Please observe that during tests on one side, the other has either to be connected to an fitted spark plug or securely earthed/grounded. Otherwise there will be no spark on either side. Also with such open exits long and dangerous sparks may fly all over the coil.

- Never do electric arc welding on the bike without completely disconnecting all parts containing semiconductors (ignition coil, regulator, advance) stator and rotor need not be taken off. The same is true for soldering. Before touching electronics disconnect the soldering iron from mains! Never use copper putty on spark plugs.

- Electronics are very sensitive to wrong polarity. After work on the system, do check correct polarity of the battery and the regulator. Wrong polarity creates short circuits and will destroy the regulator, the ignition coil and the advance unit. As a rule, wiring will always be colour to colour. Instances, where colour jumps between wires are expressly mentioned in our instructions.

- When you handle the new rotor, take care not to damage its magnets. Refrain from direct blows to the circumference of the rotor. **When transporting never put the rotor over the stator.** Observe our information relative to transport of the material.

- Do not use spark plug sockets with a resistance of more than 5kOhm. Better use 1 or 2kOhm ones. Bear in mind that spark plug sockets do age and thereby increase their internal resistance. Should an engine start up only when cold, a defective spark plug socket and/or spark plug is very probably the cause. In case of problems check high tension cables too. Never use carbon fibre HT-cables, never use so called "hot wires" which promise to increase spark.

- It is a good idea to cover the rotor in a thin layer of oil to reduce the risk of corrosion.

- Never use a claw puller or a hammer to disengage the rotor. Its magnets might become loose in the event. We offer a special puller for disengaging the new rotor again (see assembly instruction)!

- Should the motorcycle not be in use for some longer period, please disconnect the battery (so existing) to prevent current bleeding through the diodes of the regulator. Though, even a disconnected battery will empty itself after a while.

- Please do observe these remarks, but at the same time, don't be afraid of the installation process. Remember, that before you, thousands of other customers have successfully installed the system.  
***Enjoy driving your bike with its new electric heart!***



## Schaltplan 9519 (wiring diagram)

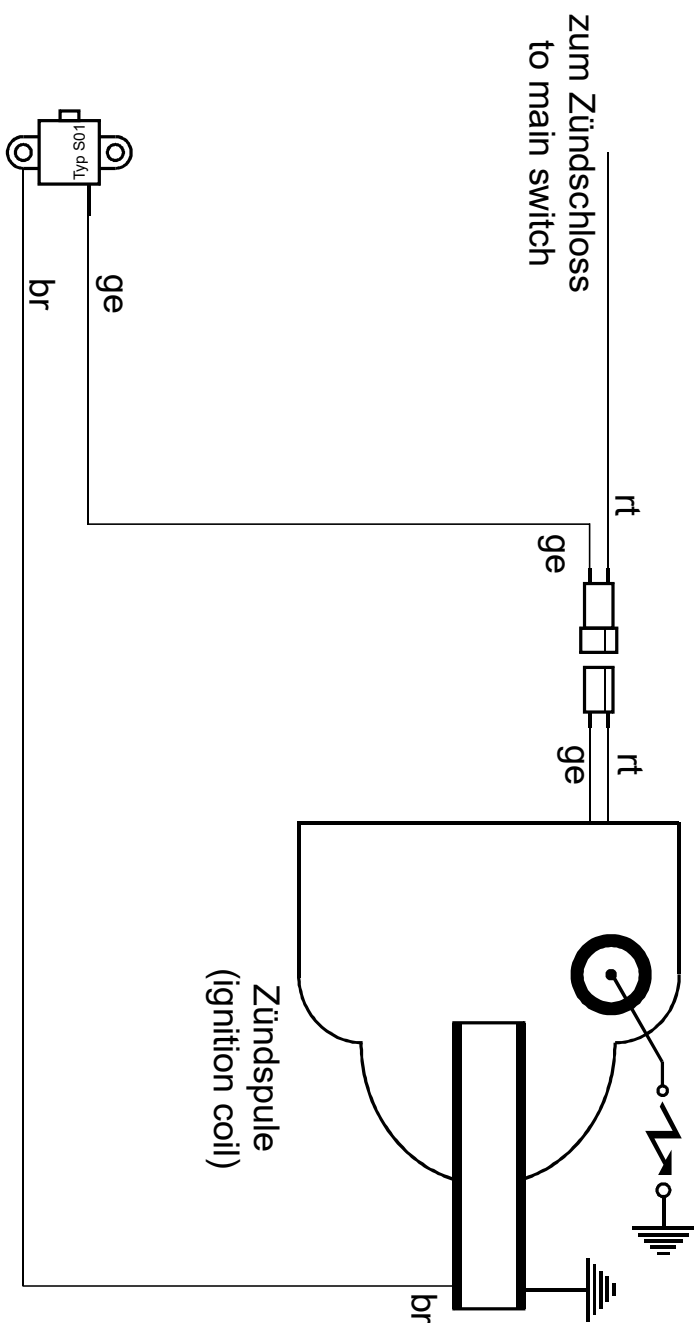

Kabelfarben (wiring colours):	
bl	= blau (blue)
br	= braun (brown)
ge	= gelb (yellow)
gr	= grün (green)
rt	= rot (red)
sw	= schwarz (black)
ws	= weiß (white)